

CD Series 5 Drive with AKM Motor Incremental Encoder Single Ended Halls based system

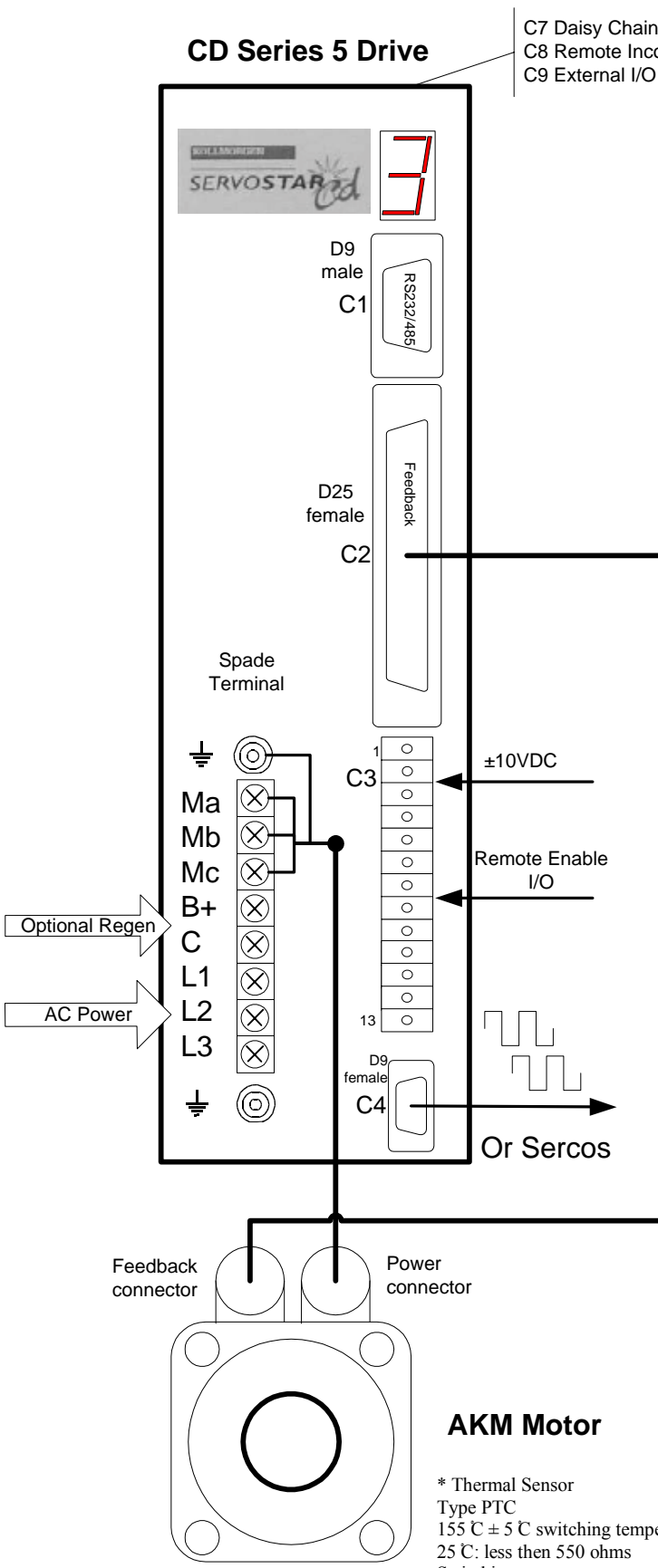

"C" Connector option



Feedback cable

Drive Feedback C2		Motor feedback connector	
1	A	1	B green
2	A\	2	B\ green/black
3	Shield		
4	B	3	A blue
5	B\	4	A\ blue/black
6	Shield		
7	5V RTN	7	GND black
8			
9	H1b	17	W white
10	H2b	16	V grey
11	H3b	15	U brown
12	Shield		
13	Thermostat High	8	*Thermal Sensor
14	Shield		
15	Index	5	Z violet
16	Index\	6	Z\ violet/black
17	Shield		
18	5V Supply		
19	5V Supply	10	Vcc
20	5V Supply		
21	Shield		
22	H1a Tie to pin 18		
23	H2aTie to pin 18		
24	H3a Tie to pin 18		
25	Thermostat Low	9	*Thermal Sensor

Power cable

Drive Power		Motor Power connector	
GND	Ground	2	PE grn/yel
Ma	Phase A **Bluw	3	W violet
Mb	Phase B **White	4	V brown
Mc	Phase C **Black	1	U blue
		A	Brake +
		B	Brake -

** Colors of standard KM cable



"M" Connector option

Feedback cable

Drive Feedback C2		Motor feedback connector		
1	A	1	B	green
2	A\	2	B\	green/black
3	Shield			
4	B	3	A	blue
5	B\	4	A\	blue/black
6	Shield			
7	5V RTN	7	GND	black
8				
9	H1b	17	W	white
10	H2b	16	V	grey
11	H3b	15	U	brown
12	Shield			
13	Thermostat High	8	*Thermal Sensor	white/orange
14	Shield			
15	Index	5	Z	violet
16	Index\	6	Z\	violet/black
17	Shield			
18	5V Supply	10	Vcc	red
19	5V Supply			
20	5V Supply			
21	Shield			
22	H1a Tie to pin 18			
23	H2a Tie to pin 18			
24	H3a Tie to pin 18			
25	Thermostat Low	9	*Thermal Sensor	orange

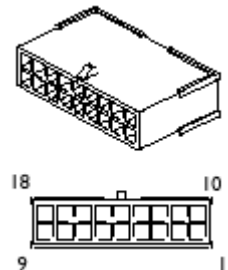

Power cable

Drive Power		Motor Power connector		
GND	Ground	5	Shield	yellow/green
Ma	Phase A	3	W	violet
Mb	Phase B	2	V	brown
Mc	Phase C	1	U	blue
		A	Brake +	
		B	Brake -	

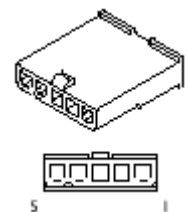

Hall sensor transition table

Relevant commands: HALLS , MHINVA, B, C, MFBDIR

Note- Motion link Feed back screen replay Ha Hb Hc where Halls command replay Hc Hb Ha

The correct hall effect commutation is obtained by the following hall sensor states from "0" position through one electrical cycle. (CW rotation).

ZERO 2, IZERO

The ZERO command places the motor in a fixed electrical position by applying a constant current between phases .

ZERO 2 (A-B)

Electrical Degree CW	Hall states A B C
0 - 60	1 0 0
60 - 120	1 0 1
120 - 180	0 0 1
180 - 240	0 1 1
240 - 300	0 1 0
300 - 360	1 1 0

Red marks hall transition

Encoder Characteristics				
Menctype	A/B	Marker Pulse	Absolute position	comments
0	x	x	Hall Effects	A/B/Z/H
1	x	x		A/B/Z ENCSTART, ENCINIT
2	x	x		A/B/Z ENCSTART, ENCINIT
3	x			Wake & Shake ENCSTART
4	x			Wake & Shake on power up K & ENCSTART
6	x		Hall Effects	A/B/H

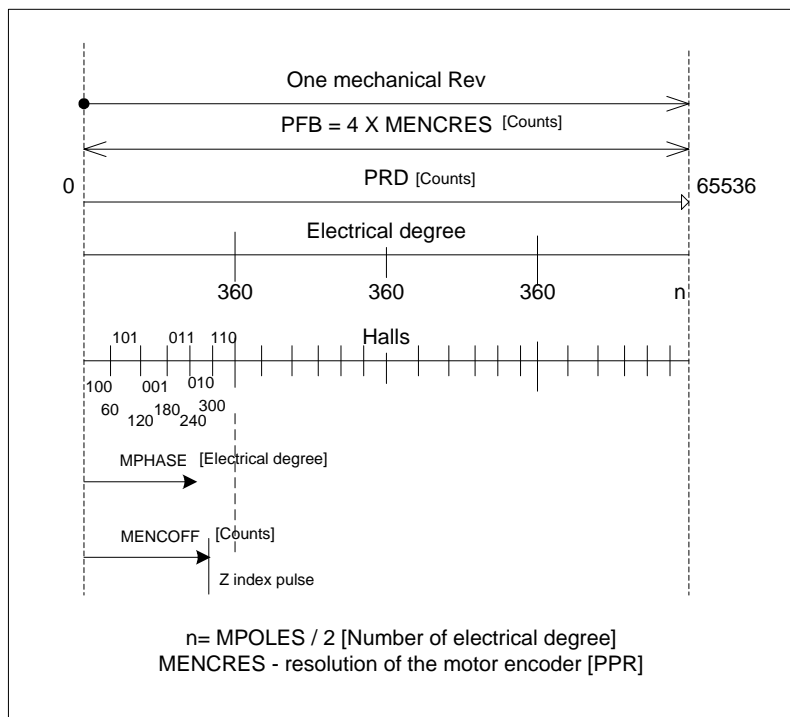

$$\text{MENCOFF} = \frac{\text{MENCRES} \times 4}{\text{MPOLES}} \times \frac{\text{degree}\{\text{HallsTransition_Where_IndexIsHigh}\}}{360}$$

Typical value for AKM:

ENCINITST switch to 2 when Halls (ABC switch from 011 to 010) or (CBA from 110 to 010) which is 240 degree

For MENCRES 2048 MPOLES 6, MENCOFF = 2048x4/6 x 240/360 = 1820

For MENCRES 5000 MPOLES 6, MENCOFF = 5000x4/6 x 240/360 = 4444

Note- Motion link Feed back screen replay Ha Hb Hc where Halls command replay Hc Hb Ha

Establishing MENCOFF Setting

The MENCOFF variable holds a marker offset and is used to align the commutation in MENCTYPES 0, 1, and 2.

To determine the setting for MENCOFF perform the following steps using the SEPLink or MOTIONLINK® terminal mode with power on the drive and C3 unplugged (disabled):

1. Enter 'ENCINIT'.
2. Rotate the motor shaft two turns clockwise, by hand
3. Verify that the process is complete by entering 'ENCINITST'. should return '2' if complete.
4. If not, repeat steps 2 and 3.
5. Enter 'SAVE'.
6. Use caution to continue testing the system.
7. The MENCOFF variable may be manually trimmed for best performance.

It is common for repeated tries of this procedure to return values that are significantly different due to the software's reference point being different from try- to- try. This is normal.

Note: The motor shaft must be free to rotate uncontrolled without damage to equipment or personnel.

Nomenclature

Historically Kollmorgen motor phases have been designated with the letters 'A', 'B', and 'C' for each of the 3 phase connections. The new AKM motors are labeled 'U', 'V', and 'W'. The relationship of these signals is shown in the following table:

CD Nomenclature	AKM Nomenclature
Phase A	Phase W purple
Phase B	Phase V brown
Phase C	Phase U blue

This translation is important to both the motor lead connections and hall sensor connections as they relate to the commutating encoder versions of the AKM motor series.

Compatible Firmware and Motion Link Revisions

CD Series 5 firmware version 7.0.3, or later, should be installed in the drive. Motion Link version 4.5.0 or later should be installed on the computer. A file named AKM.MO3 must be present in the Motion Link directory.

New MOTORTYPE

The MOTORTYPE variable in the CD-Series drive was installed to allow translated units for rotary or linear motors. A new MOTORTYPE argument, 3, has been added in firmware version 7.0.3 and supported by Motion Link 4.5.0.

Note: for Firm ware up to 7.1.9 you should use MOTORTYPE 0 from Firmware 7.1.10 you can use both MOTORTYPE 0 and 3 will give you MPHASE = 0

Encoder-Based Alignment issues

The AKM motor is offered with two different line count encoders; 1024 and 2048. The published databases assume that the 2048 encoder is chosen. In the event that a 1024 line count encoder is used the Variable MECOFF must be set to ½ of the value defined for a 2048 line count encoder.

MECNOFF can be calculated using the following equation:

$$\text{MENCOFF} = \text{MENCRES} \times 4 / (\text{MPOLES}/2) \times 240/360$$